

1 Fig. 9.1 shows a circuit containing a battery, three resistors and an ammeter.

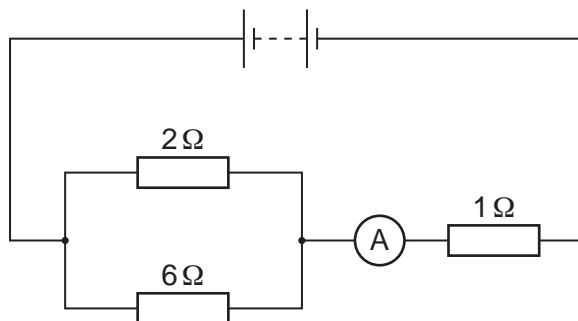

**Fig. 9.1**

- (a) (i) Write down the equation for the effective resistance  $R_p$  of two resistors of resistances  $R_1$  and  $R_2$  connected in parallel.
- (ii) Use this equation to calculate the effective resistance of the two resistors in parallel in Fig. 9.1.

effective resistance = ..... [2]

- (b) A voltmeter is to be used to measure the potential difference across the resistors in parallel.
- (i) On Fig. 9.1, draw the voltmeter in position in the circuit, using the correct circuit symbol.
- (ii) The ammeter reads 1.6A. Calculate the reading on the voltmeter.

voltmeter reading = ..... [3]

(c) State what happens to the ammeter reading if the  $1\ \Omega$  resistor is replaced by a  $3\ \Omega$  resistor.

.....  
..... [1]

[Total: 6]

- 2 Fig. 7.1 shows a circuit containing a 12V power supply, some resistors and an ammeter whose resistance is so small that it may be ignored.

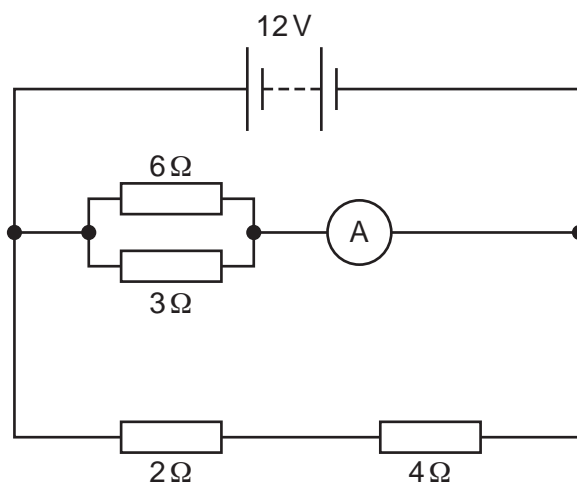

Fig. 7.1

- (a) (i) Determine the potential difference across the  $2\ \Omega$  resistor.

potential difference = .....[1]

- (ii) State the potential difference across the  $3\ \Omega$  resistor. .... [1]

- (b) Calculate the effective resistance of

- (i) the  $2\ \Omega$  and  $4\ \Omega$  resistors connected in series,

resistance = .....[1]

- (ii) the  $3\ \Omega$  and  $6\ \Omega$  resistors connected in parallel.

resistance = .....[2]

(c) Calculate the reading on the ammeter.

ammeter reading = .....[2]

(d) Without further calculation, state what happens, if anything, to the ammeter reading if

(i) the  $2\Omega$  resistor is shorted out with a thick piece of wire,

.....

(ii) the thick piece of wire from (d)(i) and the  $3\Omega$  resistor are both removed.

.....

[2]

[Total: 9]

- 3 The circuit in Fig. 9.1 contains a 4.0V battery, whose resistance can be ignored. There are also three resistors, a 3-position switch, S, and another component, P.

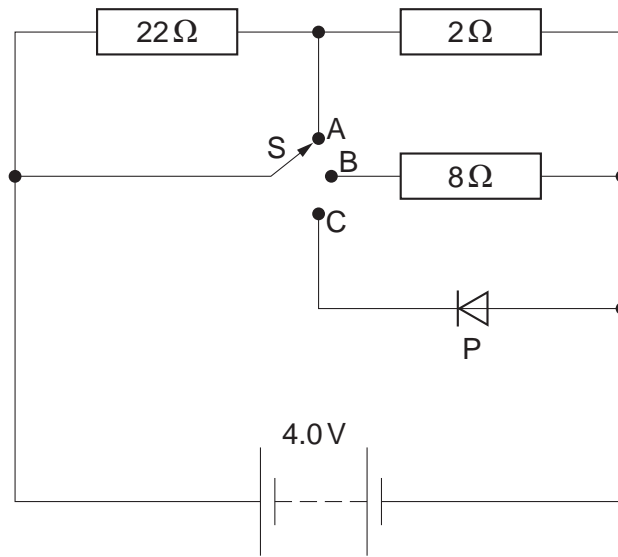

**Fig. 9.1**

- (a) State the name of component P.

..... [1]

- (b) Deduce the resistance of the circuit when switch S is connected to

- (i) point A,

resistance = ..... [1]

- (ii) point B.

resistance = ..... [3]

(c) State the current in component P when S is in position C, and explain your answer.

current = .....

explanation .....

.....

.....

..... [2]

(d) The  $22\Omega$  resistor is removed as shown in Fig. 9.2.

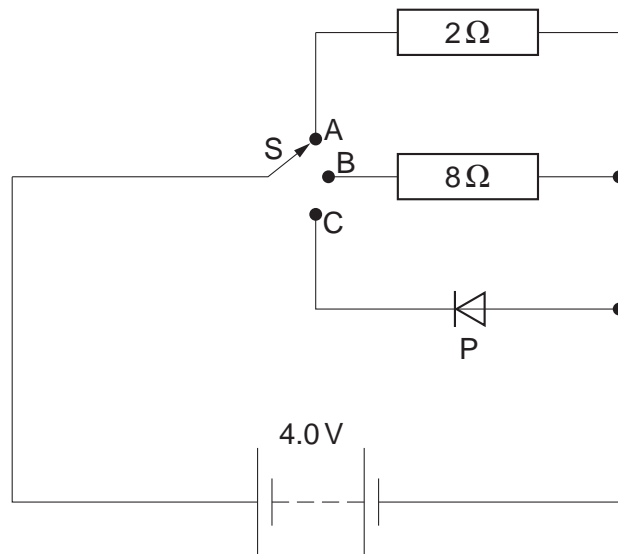

**Fig. 9.2**

Showing your working, decide which switch position will result in energy release from the circuit at the rate of  $2.0\text{W}$ .

switch position = ..... [3]

[Total: 10]

- 4 The circuit in Fig. 8.1 contains a 2.0V cell, whose resistance you should ignore. There are also three resistors, a 3-position switch, an ammeter and another component, P.

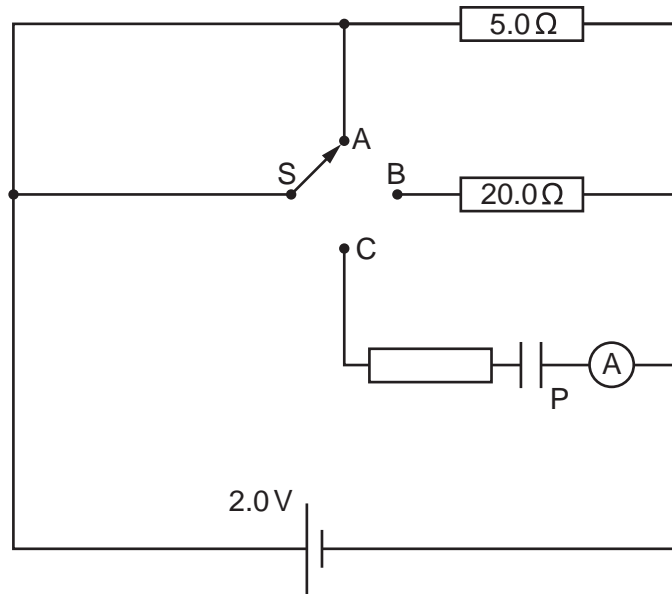

Fig. 8.1

- (a) State the name of component P. .... [1]
- (b) Deduce the resistance of the circuit when switch S is
- (i) in position A,

resistance = ..... [1]

(ii) in position B.

resistance = ..... [3]

(c) Describe and explain what is seen on the ammeter when S is moved to position C.

.....  
.....  
.....  
..... [2]

(d) With S in position A, calculate how long it takes for the circuit to transfer 320J of electrical energy to other forms.

time taken = ..... [3]

[Total: 10]



- 5 (a) Fig. 9.1 shows an a.c. supply connected in series to a diode and a resistor.

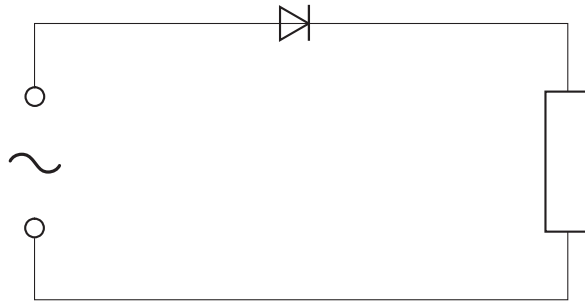

**Fig. 9.1**

On the axes of Fig. 9.2, draw a graph showing the variation of the current in the resistor. [1]

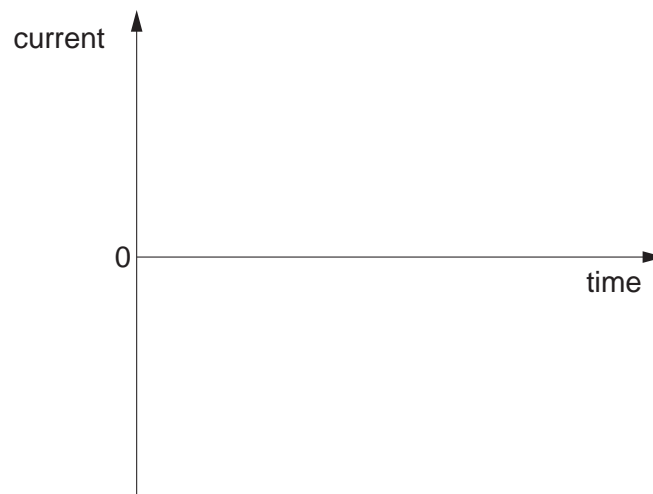

**Fig. 9.2**

(b) Fig. 9.3 shows four attempts, **A**, **B**, **C** and **D**, to connect a circuit known as a bridge rectifier.

The circuit is connected to a 12V a.c. supply.

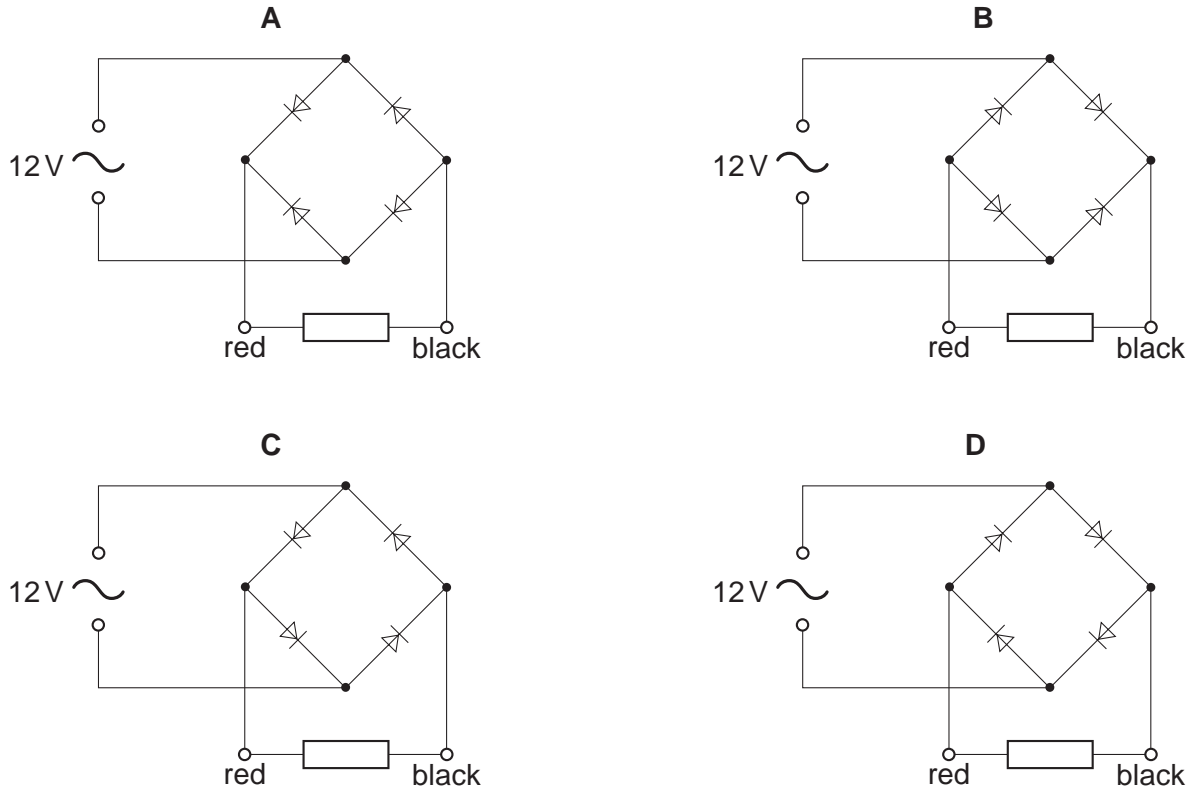

**Fig. 9.3**

(i) In which circuit will the direction of the conventional current in the resistor always be from red to black?

..... [1]

(ii) On the circuit you chose in (b)(i), clearly indicate with arrows the path of the conventional current in the circuit when the upper terminal of the a.c. supply is positive with respect to the lower terminal. [2]

[Total: 4]

1 The circuit shown in Fig. 10.1 uses a 12V battery.

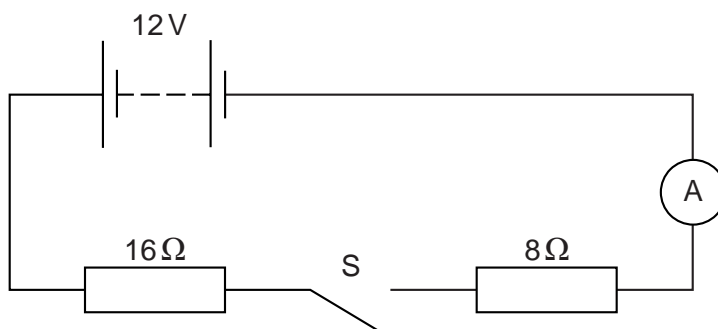

Fig. 10.1

(a) Switch S is open, as shown in Fig. 10.1.

State the value of

(i) the reading on the ammeter,

reading = ..... [1]

(ii) the potential difference (p.d.) across S.

p.d. = ..... [1]

(b) Switch S is now closed.

(i) Calculate the current in the ammeter.

current = ..... [2]

(ii) Calculate the p.d. across the 8Ω resistor.

p.d. = ..... [2]

(c) The two resistors are now connected in parallel.

Calculate the new reading on the ammeter when S is closed, stating clearly any equations that you use.

reading = ..... [4]

[Total: 10]

2 Fig. 8.1 is the plan of a small apartment that has four lamps as shown.

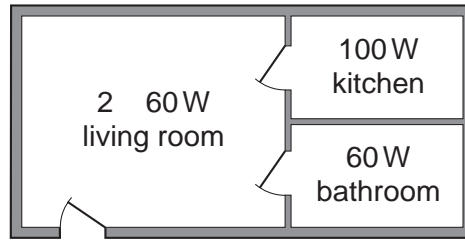

**Fig. 8.1**

Power for the lamps is supplied at 200V a.c. and the lamps are all in parallel.

(a) In the space below, draw a lighting circuit diagram so that there is one switch for each room and one master switch that will turn off all the lamps. Label the lamps as 60W or 100W.

[3]

(b) The 100W lamp is switched on. Calculate

(i) the current in the lamp,

current = ..... [2]

(ii) the charge passing through the lamp in one minute.

charge = ..... [2]

(c) The three 60W lamps are replaced by three energy-saving ones, that give the same light output but are rated at only 15W each.

Calculate

(i) the total reduction in power,

reduction in power = ..... [1]

(ii) the energy saved when the lamps are lit for one hour.

energy saved = ..... [2]

[Total: 10]